

HS-900A Technical Data Sheet

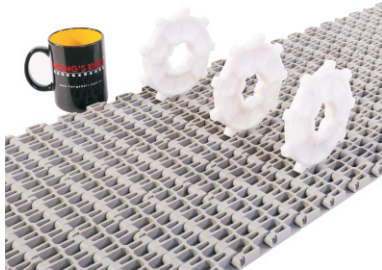
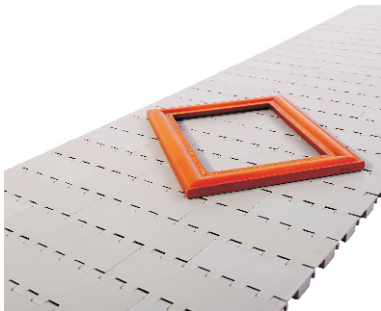
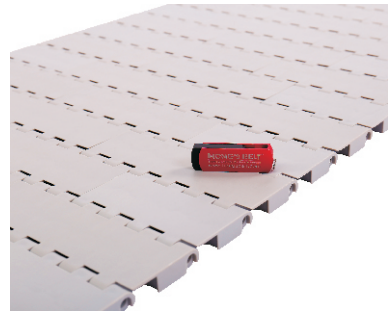

Pitch: 50.8mm Minimum Width: 150mm Open Area: 0% Approved: FDA Rod: Ø 5.8mm Flight: Yes Side Guard: No Curve: No	
---	--

Data

Belt Material	Belt Strength			Temperature		Belt Weight (Kg/M ²)
	Straight		Curve	°C (min.)	°C (max.)	
	Kg/M(BW)	N/M(BW)				
Polypropylene	2745	27450	--	1	100	6.6
Polyethylene	2610	26100	--	-60	60	7.4
Acetal	3090	30900	--	-40	80	9.5
Nylon	2400	24000	--	1	180	8.5
HK	2780	27800	--	-40	80	9.0

BW – Belt Width

Color Table

Polypropylene				Polyethylene				Acetal				Nylon							
W	G	N	DB	B	W	G	N	DB	B	W	G	N	DB	B	W	G	N	DB	B
●	●						●			●							●		

W-White, G-Gray, N-Nature, DB-Darkbrown, B-Blue

Friction Table

Belt Material	Friction Wear strips & Products							
	UHMW	HDPE	Steel	Glass	SUS	Plastic	Cardboard	Aluminum
Polypropylene	0.32	0.24	0.15	0.09	0.13	0.08	0.15	0.25
Polyethylene	0.13	0.11	0.26	0.19	0.31	0.16	0.21	0.41
Acetal	0.11	0.09	0.27	0.16	0.26	0.15	0.19	0.28
Nylon	0.18	0.13	0.25	0.16	0.26	0.16	0.19	0.27

SUS – Stainless Steel

Equivalent type with other Brand

Brand Name	Intralox	UNI	Rexnord	MCC	Habasit	KVP
Series & Type	400	OPB	2000	2000	5000	620
	200	L-SNB	6390	--	5100	620ST
	800/850	MPB	2010	--	--	620IB

The above content is only for reference.

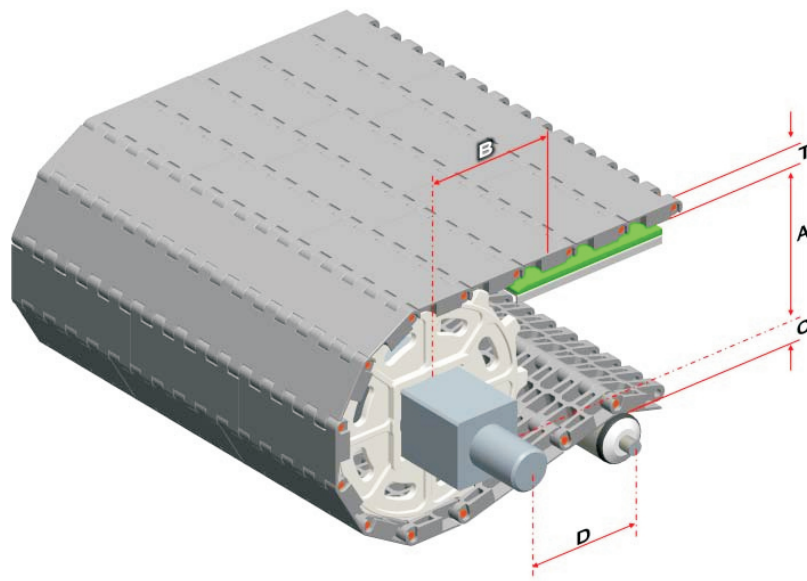

Conveyor Frame Dimensions

Unit : mm

No. Teeth	A (Min.)	B (Min.)	C (Max.)	D (Min.)	T
6	41	58	38	250	14
9	66.5	83.5	63.5	250	
12	90.75	107.75	87.75	300	

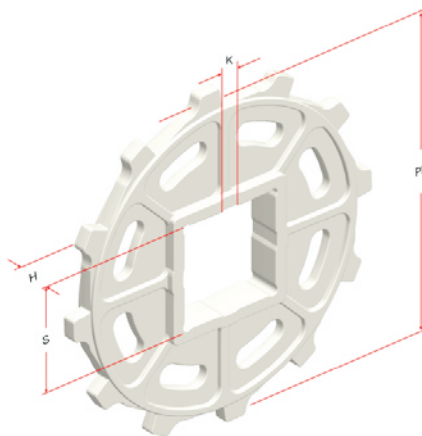

Sprocket Dimensions

Unit: mm

No. Teeth	PD	S	D	H	K
6	96	38.5/40.5	45.5/47.5	20	7X7
9	147	38.5/40.5/50.5	25.5/30.5/31.75/40.5/47.5/50.5	12	8X8
12	195.5	38.5/40.5/60.5/63.5	--	12	--